



February 14, 2017

## Rules Clarifications #RC0001

To All F4 Teams:

Mike Wright has received several inquiries regarding F4 U.S. Rules. You'll find the questions outlined below. All tech questions should be fielded to Mike Wright: [mwright@sccapro.com](mailto:mwright@sccapro.com)

## Responses To Team Inquiries – Pre Season 2017

- i) Fuel and oil lines are to remain as delivered by Onroak. Shortening, or the addition of heat shielding, or screening, are not permitted.
- ii) Allowable front wickers:

**Crawford F4-16 homologated front wing gurneys listed below may be used.**

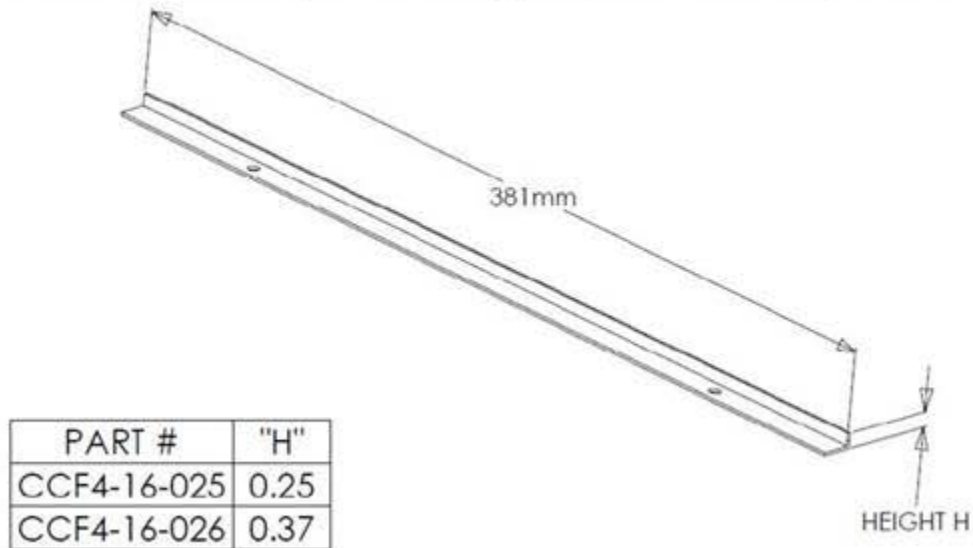

Honda Racing  
LED & V

PIRELLI

RI  
shocks

SCCA  
PRO RACING

onroak  
AUTOMOTIVE

UNITED STATES  
CHAMPIONSHIP



- iii) To aid front cowl location, self-adhesive Velcro is presently the only addition that is allowed.
- iv) Heat shielding of the intake plenum is not permitted.
- v) WRD is presently the only approved gearbox service center.
- vi) The only approved driver dead pedal is the one detailed in Onroak F4 Bulletin F4.02.11.23.
- vii) The only permitted radiator inlet duct stone guards are those supplied by Onroak. Competitors have the option of running those or none.
- viii) Overall width - per 2017 FIA F4 Technical Regulations:

**3.3** Overall width: *The overall width of the car including complete wheels shall not exceed 1750 mm, with the steered wheels in the straight-ahead position.*

$$1750\text{mm} = 68.90''$$

- ix) The wooden skid cannot be cut into two pieces. It can be sealed with a clear varnish to prevent it from absorbing water.
- x) A jump plug can be fitted for a slave battery to assist engine starting. *(Competitors' attention is drawn to Rule 39.5 b) of the Sporting Regulations).*
- xi) SCCA Pro Racing will issue the Accident Data Recorders at a time to be advised.

